



TECNOASTEPAN GROUP

MACCHINE PER LA PANIFICAZIONE
BAKERY MACHINE

**GRISSINATRICE AUTOMATICA
AUTOMATIC BREAD-STICK FORMING MACHINE**



Made in Italy

MGA 180



TECNOASTEPAN GROUP SRLS

Prov.le Martano-Otranto, 71
73020 Carpignano Salentino (Lecce) ITALY
☎ +39 0836.1904598 ☎ +39 324.8140713
commerciale@tecnoastepangroup.com
assistenza@tecnoastepangroup.com

www.tecnoastepangroup.com

f Tecnoastepan Group @ Tecnoastepan

dal 1938

FARINELLI
DIVISIONE MACCHINE



TRAFILE STANDARD STANDARD BREAD-STICK ROLLERS	
Ø mm	N° File - N° Rows
6	23
8	18
10	15
12	13
16	10
18	9
20	7

Altre dimensioni e forme a richiesta
Other dimensions and shapes on request



Pannello di controllo
Control pannel

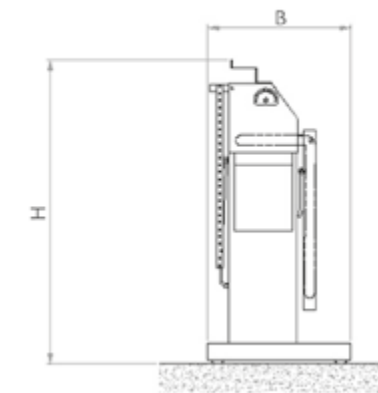
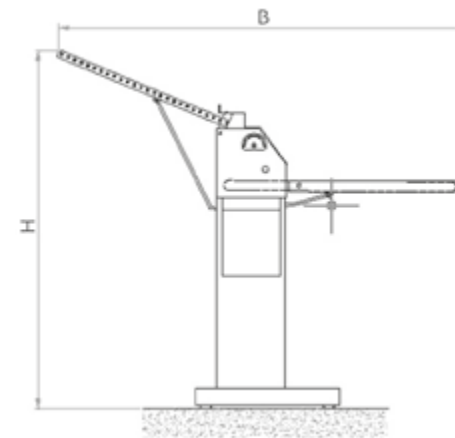
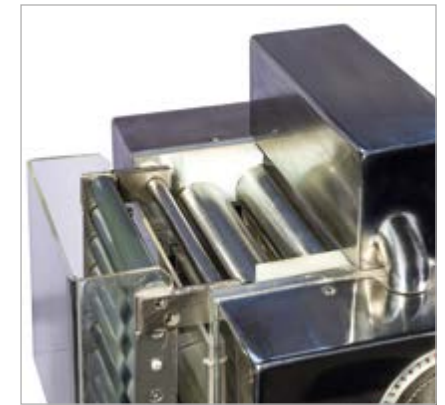

Macchina automatica per la produzione di grissini, taralli, biscotti ed altre forme trafilate.

- Ciclo di lavoro automatico
- Taglio a mezzo ghigliottina
- Regolazione elettronica della velocità del tappeto
- Regolazione elettronica della lunghezza di taglio
- Regolazione elettronica del tempo di sosta
- Rulli calibratori in ingresso
- Rulli trafilatori intercambiabili

Automatic bread-stick and biscuit making machine.

- Automatic and semi-automatic work cycle
- "Guillotine" cutting system
- Electronic speed adjustment of outlet conveyor belt
- Electronic adjustment of cutting length
- Réglage électronique du temps d'arrêt
- Calibrating rollers prior to forming
- Interchangeable forming rollers

Modello Model	Potenza elettrica Electric power rating	Peso Weight	Dimensioni macchina aperta Machine dimensions when open			Dimensioni macchina chiusa Machine dimensions when closed		
			A mm	B mm	H mm	A mm	B mm	H mm
MGA 180	Kw 0,37	Kg 80	450	1770	1500	450	650	1300